



JR2000 Touch Tablet Time Clock  
**Wall Mount**

## 06

## WALL MOUNT

Included with your time clock, you will find a metal back plate, a LAN cord, a power adapter, four drywall anchors, four screws, and two small bracket screws. You will need your own Phillips-head screwdriver.

### MOUNTING YOUR TIME CLOCK ONTO YOUR WALL

1. Select a location for your time clock near a power outlet and LAN port (if applicable).
2. Place the provided mounting template against the wall (shown at right). Drill holes through the targets using a 1/4" (6.35mm) drill bit.
3. Insert drywall anchors into the center of the wall marks.
4. Align the metal back plate with the holes. Ensure that the prongs are facing away from the wall, then secure the back plate to the wall with the included screws.
5. Attach the power adapter and the LAN line (if applicable).
6. Align the two slots on the back of the clock with the two prongs on the back plate. Push down slightly to ensure the clock is securely fastened.
7. Optionally screw the time clock to the metal back plate with the included bracket screws at the bottom of the time clock.

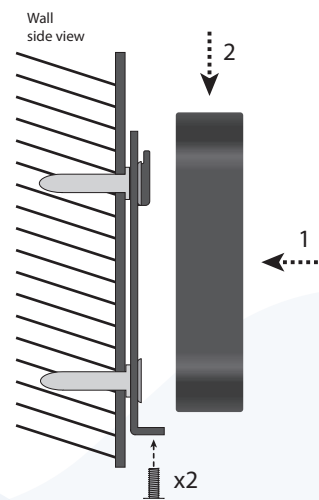
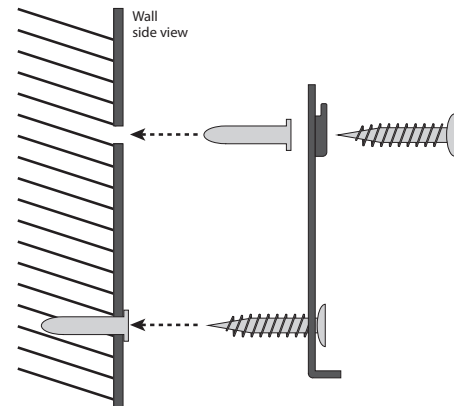
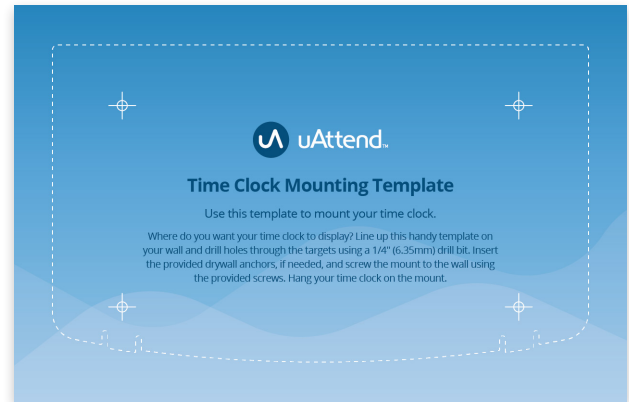

## uATTEND DEVICE LIMITED WARRANTY

This Warranty covers all uAttend Devices and any Devices which may now or in the future be connected to your uAttend Account.

- A. **Warranty and Warranty Periods.** Workwell Technologies, Inc. (“WWTech”) warrants only to the original Purchaser that the Device will be free from defects in material and workmanship for the time during which (i) the original Purchaser subscribes to the uAttend System, and (ii) until such time the Device has been replaced (the “Warranty Period”).
- B. **WWTech’s Obligation Under Warranty.** WWTech’s sole obligation under the above warranty shall be to repair or replace Devices and parts during the Warranty Period. WWTech does not assume responsibility for delays in replacement or repair of products or parts. WWTech may, at its sole discretion, replace Devices with refurbished Devices. This warranty gives end users specific legal rights, and particular end users may also have other rights which may vary from jurisdiction to jurisdiction.
- C. **DISCLAIMER OF ALL OTHER WARRANTIES.** NO OTHER WARRANTIES, EXPRESSED OR IMPLIED, ARE GIVEN, AND WWTech EXPRESSLY DISCLAIMS ALL OTHER WARRANTIES, INCLUDING AND WITHOUT LIMITATION, THE IMPLIED WARRANTIES OF MERCHANTABILITY AND FITNESS FOR A PARTICULAR PURPOSE. Some jurisdictions do not allow limitations on how long an implied warranty lasts, so the above limitation may not apply to particular end users.
- D. **Limitations.** No salesperson, representative, or agent of WWTech is authorized to make any guaranty, warranty, or representation that contradicts the terms contained in this Limited Warranty. Any waiver, alteration, addition, or modification to the warranties contained herein must be in writing and signed by authorized representatives of WWTech to be valid, binding, and enforceable. WWTech does not assume responsibility for any specific application to which any products or parts are applied including, but not limited to, compatibility with other equipment. All statements, technical information, or recommendations relating to the products or parts are based upon tests believed to be reliable, but do not constitute a guaranty or warranty. WWTech SHALL NOT UNDER ANY CIRCUMSTANCES WHATSOEVER BE LIABLE TO ANY PARTY FOR LOSS OF PROFITS, DIMINUTION OF GOOD WILL, OR ANY OTHER SPECIAL, CONSEQUENTIAL, OR INCIDENTAL DAMAGES WHATSOEVER WITH RESPECT TO ANY CLAIM IN CONNECTION WITH WWTech PRODUCTS AND/OR PARTS. Some jurisdictions do not allow the exclusion or limitation of incidental or consequential damages, so the above limitation or exclusion may not apply to particular end users.

- E. What May Void the Warranty. This Limited Warranty shall be null and void in the following circumstances:
1. Modification or repair by the end user or any non-authorized WWTech service provider; or
  2. Improper use or installation, or damage by accident or neglect, by the end user or any third party, or intentional damage by the end user or any third party; or
  3. Failure of the end user or any third party to exercise caution to protect from electrostatic discharge damage and adverse temperature, or physical abuse; or
  4. Failure by the end user to follow the Return Appointment Process set forth below.
- F. Return Appointment Process. As a condition precedent to the above Limited Warranty, the end user must:
1. Obtain a return material authorization (RMA) from WWTech, which will include an RMA number that must be prominently displayed on the outside of the shipping container. Returns without an RMA number may be rejected by WWTech and immediately returned to end user, freight collect.
  2. Ship the items being returned to WWTech, freight prepaid, together with a written description of the claimed defect.
  3. Pack the items being returned in the original packing carton or equivalent. Damage in transit is end user's responsibility and may be cause to void the warranty claim.
- G. Transportation Costs. WWTech will pay surface freight to return products covered by this Limited Warranty. However, if WWTech determines in the exercise of its reasonable but sole discretion that the product or part returned for warranty service is not defective, or does not otherwise qualify for warranty service, the end user shall be liable for all costs of handling and transportation.

# 11

## uATTEND SAFETY INFORMATION

IMPORTANT SAFEGUARDS FOR SAFE OPERATION & USE

### SAVE THESE INSTRUCTIONS.

THIS PRODUCT IS FOR COMMERCIAL USE ONLY.

The time clock is an electrical device. In order to reduce the risk of fatal electrical shock and fire, basic safety precautions should be followed, including the following:

1. Read all instructions before operating.
2. This time clock must be properly installed and located in accordance with these instructions before used.
3. Do not use outdoors.
4. Do not expose to water or any liquid.
5. Do not place objects into the time clock.
6. For best operation, plug the time clock into its own electrical outlet.
7. Do not operate the time clock with a damaged cord or plug.
8. If an extension cord is used, the marked electrical rating of the extension cord should be at least as great as the electrical rating of the time clock.
9. Plug the time clock into a surge protector or uninterruptible power supply (UPS). If a surge protector is not used and there is a power surge, your warranty may be voided.



**CAUTION/WARNING**



**DANGEROUS VOLTAGE**



**DO NOT CONNECT  
DAMAGED SUPPLY CORD**

### **WARNING**

**RISK OF FIRE OR ELECTRIC SHOCK  
DO NOT OPEN**

**WARNING:** TO REDUCE THE RISK OF FIRE OR ELECTRIC SHOCK, DO NOT OPEN THE TIME CLOCK. NO USER SERVICEABLE PARTS ARE INSIDE. REPAIRS SHOULD BE COMPLETED BY AUTHORIZED SERVICE PERSONNEL ONLY.



**QUESTIONS?** Call 800-518-8925 or Email [support@trackmytime.com](mailto:support@trackmytime.com)



## Questions?

Contact us seven days a week.

Monday-Friday 5am-6pm Pacific

Saturday-Sunday 7am-3:30pm Pacific

**Call** 800-518-8925

**Text** 760-278-6623

**Email** [support@trackmytime.com](mailto:support@trackmytime.com)

**Visit** [support.trackmytime.com](http://support.trackmytime.com)



Designed, Developed, and Supported by Workwell Technologies, Inc.  
© Workwell Technologies, Inc. All rights reserved.  
2777 Loker Avenue Suite A Carlsbad CA 92010  
[workwelltech.com](http://workwelltech.com)